

P Kaboo Prop

Tools needed

Pencil or pen	11mm or 7/16" socket
Drill	11mm or 7/16" wrench
3/32" drill bit	13mm wrench
1/4" drill bit	10mm wrench
3/16" drill bit	Mini flathead screw driver
#2 (cross tip) screw driver or drill bit	Wire cutters/strippers
Socket wrench	Wire crimpers
10mm socket	Water spray bottle

Parts list

1 - 5V 5A power brick	1 – switch arm
1 – 5V 2A power supply	1 – motor mount arm
1 – USB to USB-C cable	1 – frame with 2 - 4-way PVC connectors
1 – windshield wiper motor	1 – 25” PVC lift arm
1 – wiper motor mount (fence mount)	1 – 3” PVC lever arm
1 – Arduino – preprogrammed	4 – 1-1/2” PVC spaces
1 – relay board	2 – 5” PVC tombstone extension arms
1 – microswitch	2 – 19” PVC tombstone mount arms
1 – PIR	4 – PVC elbow connectors
1 – female 5-12V connector	1 – PVC T connector
1 – PIR cable	2 – lift arm bolts 1/4”x20x2-1/2”
1 – micro switch cable	4 – carriage bolts 1/4”x20x1-3/4”
1 – relay cable	6 –1/4” nylon lock nuts
1 – short 1’ motor power cable	14 – 1/4” washers
1 – long 2’ motor power cable	4 – #6 1-1/4” screws
1 – blue wire nut	8 – #6 1-5/8” screws
2 – motor power connectors	15 – #6 1” screws
1 – motor extension	2 – small microswitch screws
2 – motor extension nuts	1 – Popsicle stick shim of microswitch
1 – prop base 24”x20”x5/8”	1 – 1/2” x 3/8” PEX pipe spacer
1 – motor base 2”x6”x11.5”	2 – jumper cables for Arduino board for delay options
1 – motor base shim 5.5”x11.5”x1/4”	1 – blank foam tombstone w/ optional base
1 – tombstone mount 10”x18”x7/16”	

Mount foam base to tombstone

This is optional for the tall tombstones but encouraged for the shorter tombstones to give them a little more height. Determine where you would like to your tombstone to sit on your base and mark the corners to know where to place it. I used toothpicks to keep things aligned but I think skewers will work better to hold the foam together and aligned while the glue dries.

Spray foam board with water where you plan to bring the two pieces together and apply a wavy bead of gorilla glue. Place the tombstone on the base and then stick a skewer on either side of the thin side of the tombstone at an angle down through the base. This should hold it from going up/down, left/right, or front/back. Set aside and let it dry.



Mount pre-bent electrical conduit to 24"x20"x5/8" wood base.

Drill two holes using a 3/16" drill bit on each of the two short legs of the electrical conduit. You will use the 4 1-1/4" screws.

First leg: Place the conduit on the prop base and center it as best you can from left to right on the 24" side. The end of the conduit legs should be near to or flush with the back of the prop base. Drive screws into one of the legs (if there is one leg that is naturally further back, mount that one first) while making sure the leg is parallel with the side of the base.

Second leg: The other leg should be positioned so that it is (or will be) parallel to the other side of the board. Move the leg forward and back to a position that makes the front two vertical parts of the frame line up with each other. Now secure the leg by driving one screw through the back hole in the conduit. Manipulate the frame from the front so that the leg is parallel. Secure with second screw.

Since the conduit bends were done by hand with a pipe bender, the conduit will need to be manipulated a bit to square it up as best you can. It doesn't have to be perfect but the prop will do better if it is close to straight and vertical. To do this step on base and attempt to bend it in the direction it needs to be bent to align everything.



Wiper motor and motor mount:

Mount wiper motor in fence mount. The shaft of the wiper motor should run parallel to the ground. Snug up the bolt using a 13mm wrench. It will need to be fairly tight but do not overtighten and crush the motor.

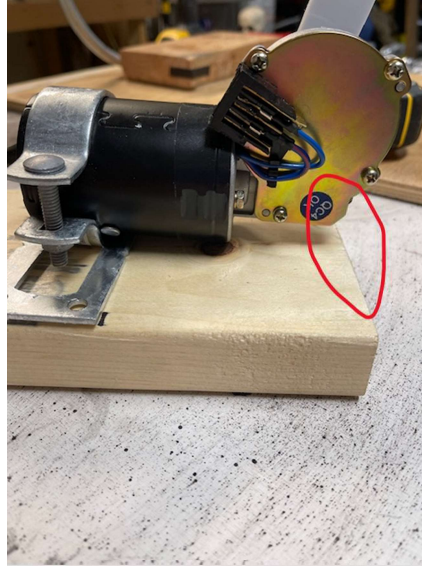

Using four 1-5/8" screws and two washers, mount the motor to the 2"x6"x11.5" motor base. The placement of the motor may be adjusted, but to start, put the motor so that the lowest part of the front of the motor lines up with the front of the motor base. The motor mount will be 4 1/8" from the front of the base. Align the motor mount so that it is near flush with the right side of the motor base.

Mark and predrill holes using a 3/32" drill bit. There will be four holes. Two through the mount holes on the right side and two holes in the little notch (see image) on the left side. Use the two washers on the sides with the notches.

Mount motor base and motor base shim (5.5"x11.5"x1/4") to main prop base. Align the motor mount base and base shim to be flush with the back of the main prop base. The right side of the motor base and shim should be aligned with the right metal conduit leg and parallel with it. It should be close to the conduit leg. You could even secure right next to it but you will probably have to move the motor over a bit from the top. This will go easier if you have help...using a 3/32" drill bit predrill 4 holes from the bottom of the base up through the motor shim and base and secure with four 1-5/8" screws.



Lift arm assembly and frame

Using four 1-1/2" PVC spacers, two PVC elbows, one tee, and one 3" PVC lever arm build the U-shape part of the lift assembly like in the picture on the left below and connect to the cross PVC fittings on the conduit frame. Press the fittings in with as much pressure as you can. The lift lever should be at about a 25-30 degree angle toward the back to start. There is no need to secure with screws yet.



Using two PVC elbows, two 5" PVC extension arms, and two 19" tombstone mount arms, build the front side of the lift assembly and connect to the cross PVC fittings. See picture for example.



Motor extension and lift arm

Assemble the plastic switch arm (hole in center of arm), motor arm extender and lift arm. Press switch arm onto motor arm then add a washer, apply a little Loctite to the threads and then screw on the motor arm extender and tighten with a 10mm wrench as tight as you can. The switch arm will bend a little bit. That is ok. You can use the switch arm for some counter pressure but don't let it spin too much or the arm hole will strip and spin freely. One way I found to tighten the extension is to quickly jerk on the wrench while applying slight pressure on the switch arm.

Add motor extension nut with the flare facing away from the motor. Add the motor lift arm using the smaller hole and then add the other nut with the flare facing the motor. The motor lift arm should be close to parallel to the switch arm. Using 10mm wrench on the inner nut and a 10mm socket on outer nut, tighten the nuts against the motor lift arm. You can get pretty good counter leverage with the wrench and the lift arm against the ratchet to tighten the bolts sufficiently to hold the lift arm. It needs to be pretty tight to be able to hold in place as it lifts and lowers the tombstone.

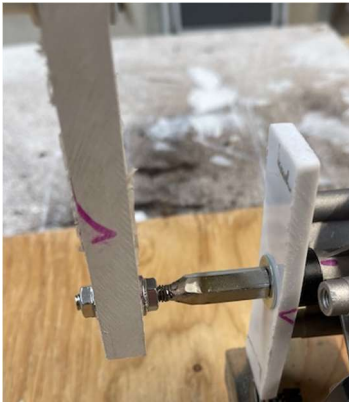

Hook up lift arm extension to motor and lift assemblies

Connect to the top half of the lift assembly by putting a 1/4"x20x2-1/2" bolt with a washer through the upper leverage arm then another washer, the 25" PVC lift arm, another washer, and finally the nylon lock nut. Tighten but leave enough play so that it can pivot freely. Use the 11mm or 7/16" wrench and socket.



Connect bottom half of the lift assembly to the motor lift arm by putting a 1/4"x20x2-1/2" bolt with a washer through the motor lift arm hole, another washer, 1/2" x 3/8" PEX pipe spacer, another washer, the 25" PVC lift arm, another washer, and the nylon lock nut. Tighten but leave enough play so that it can pivot freely. Use the 11mm or 7/16" wrench and socket.



Test run the motor and lift assembly

Assemble motor power cable by using the 2' long black cable. Strip off 1.5-2" of the black outer sheathing from each end of the cable. Strip off 1/4" off the black and red inner wires on each end. Connect the red wire to the + and the black wire to the – ports of the female 5-12V connector. Crimp on the red motor connectors to the other end of the cable. Use a very small or micro flat head screw driver to spread out the connector ends that will be pushed onto the motor.

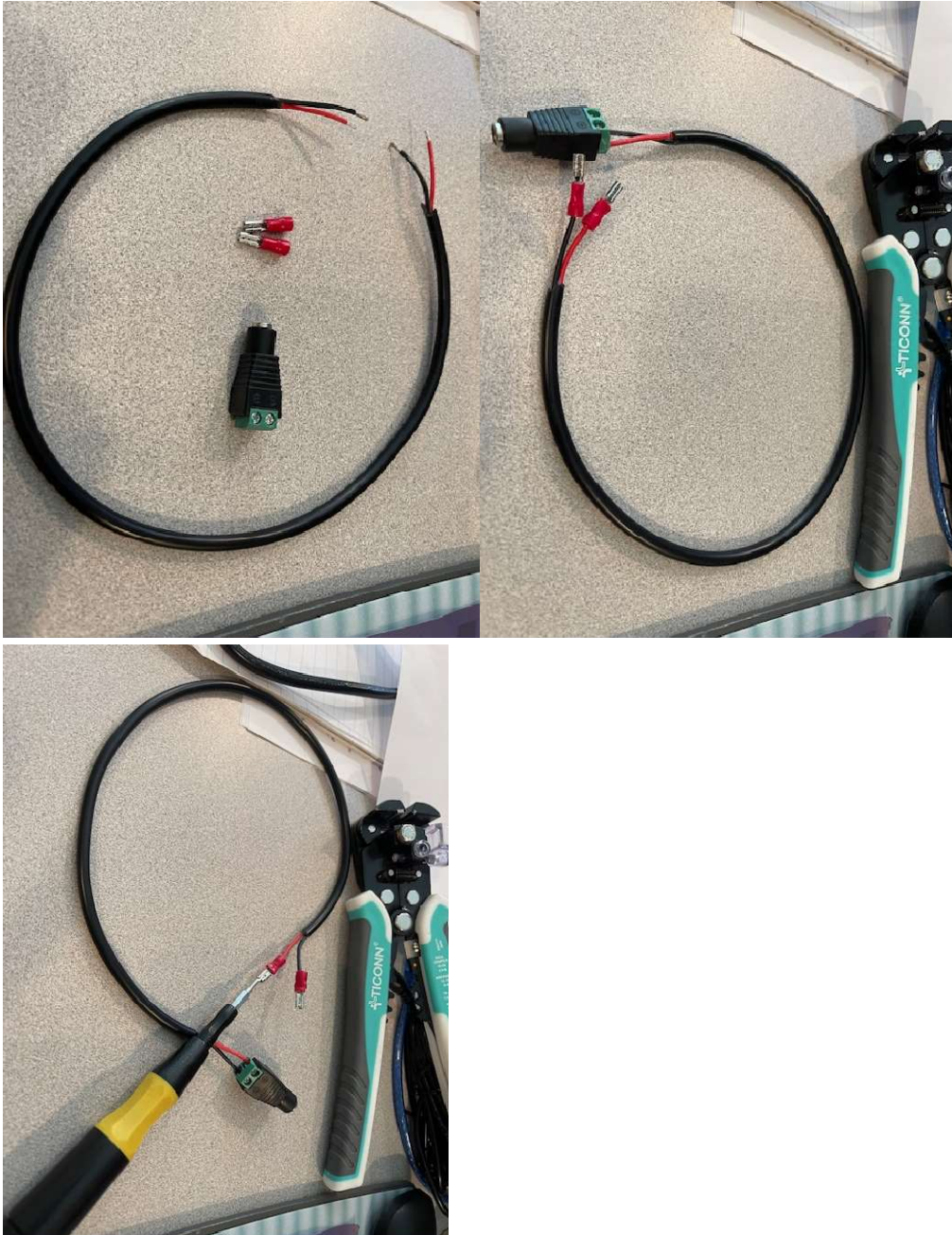

Connect the power cable ends onto the motor. The black (ground) wire connects to the top pin and the red (power) wire connect to the next one down.

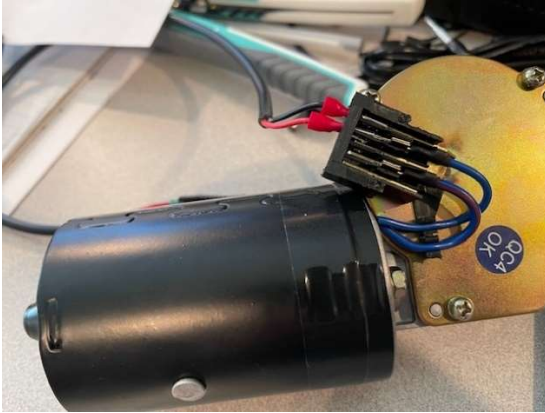

Plug the 5V 5A power brick into the other end of the motor cable and watch your prop move. The prop should move up and down freely without binding on anything. When the motor arm is up, the tombstone lift arms should be down (perpendicular to the ground) and when the motor arm is down, the tombstone lift arms should be up (parallel to the ground). You can adjust the angle of the 3" PVC lever arm and PVC "T" to change how parallel and perpendicular the lift arm will be. This angle might need to change due to the weight of the tombstone mount and tombstone, so don't worry too much if it isn't exactly aligned. You will be adjusting again later.



If something is binding on the conduit, adjust the motor position left or right to center the assembly on the metal conduit. You should also be able to adjust the PVC cross pieces on the metal conduit to reduce binding. You will want to have everything move as smoothly as possible.

The lift arms should clear the prop base. If they don't, did you forget to add the motor base shim?

Install micro switch on motor mount board

Run the motor until the tombstone comes down to its resting position with the tombstone arms perpendicular to the ground. The motor arm and switch arm should be angled slightly forward. Both arms should be parallel with each other. See image below.



Slide the micro switch from the front and underneath of the switch arm toward the back with the metal switch bar angled away from the switch arm and listen for it to click as it passes under the switch arm. The clicking sound means that the switch is engaged. If there is no click then you will need to use a shim under the switch or use duct tape on both ends of the rotating switch arm so that as it rotates, it will engage the switch. There is probably a better way to do this but this is what I came up with.



To prepare the shim (if needed), you will want to drill 1/4" holes in the shim where the screws for mounting the switch will go. This is to prevent the shim from breaking in half when mounting the switch. I also drilled the holes at an angle to prevent the shim from splitting.

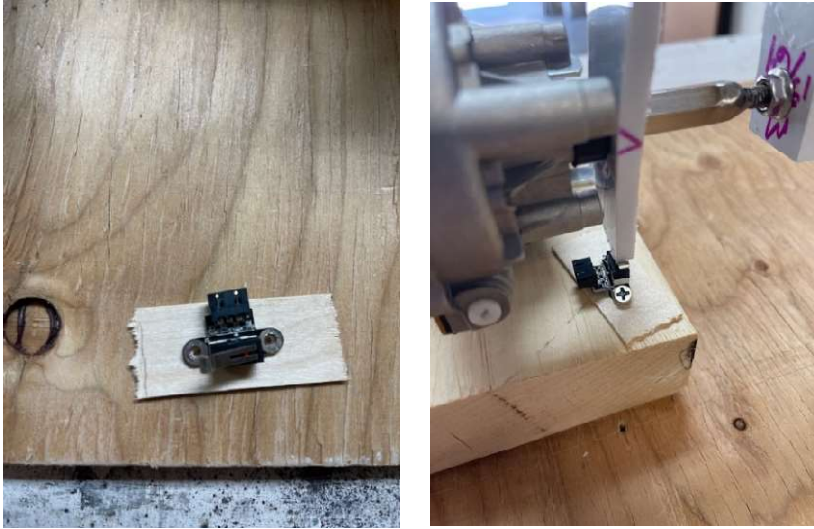

If the shim isn't quite enough to trigger the switch, you could use duct tape on each end of the rotating switch arm or you also could loosen the motor mounts for the motor bracket and rotate the motor clockwise just a bit. However, don't rotate the motor too much because you want the motor extension arm to be parallel to the ground. When the motor arm is not parallel, the lift from the motor will not be straight and it will require more from your motor to lift the tombstone.

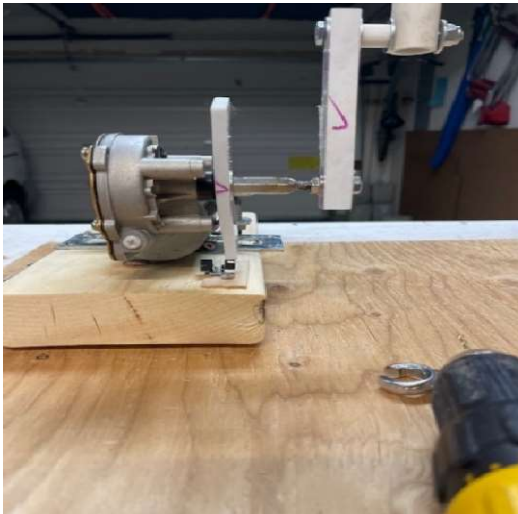

Run the power to the motor again and listen for the click each time rotating switch arm passes the switch. If it is not clicking when the tombstone lift arms are up and down, adjust accordingly.

Prepare and mount tombstone mounting plate

Drill two 1/4" holes in each of two PVC lift arms. Spread the holes apart, one near the top and one near the bottom.

Center the tombstone mounting plate on the arms and mark the hole positions on the mounting plate. Drill four 1/4" holes based on the marks you just made. Push the 1/4"x20x1-3/4" carriage bolts through the four holes. I put the rough side of the board against the carriage bolt head. My thinking is that there are more ridges for gorilla glue to stick to when gluing it to the foam. Slide the mounting plate and bolts through the PVC lift arms. Add washer and nylon lock nuts. Tighten lock nuts while putting pressure on the head of the carriage bolt. Use the 11mm or 7/16" socket.



Wire up the electronics

Disconnect the 5-12V female power connector from your power cable you built for testing.

With 1' short black power cable, strip off 1.5-2" of the black outer sheathing from each end of the cable. Strip off 1/4" off the red inner wires on each end. Strip 1/2" off the end of the black wire on both the 2' and 1' power cables.

Attach the 5-12V female power connector to the end of the short power cable that has the 1/4" stripped wire. Red on +, black on -.



Connect the red cable from the short power cable to the middle pin of the relay board. Connect the red cable from the long power cable that goes to the motor to the left (or bottom) pin. Twist the two black cables together and connect with the blue wire nut.

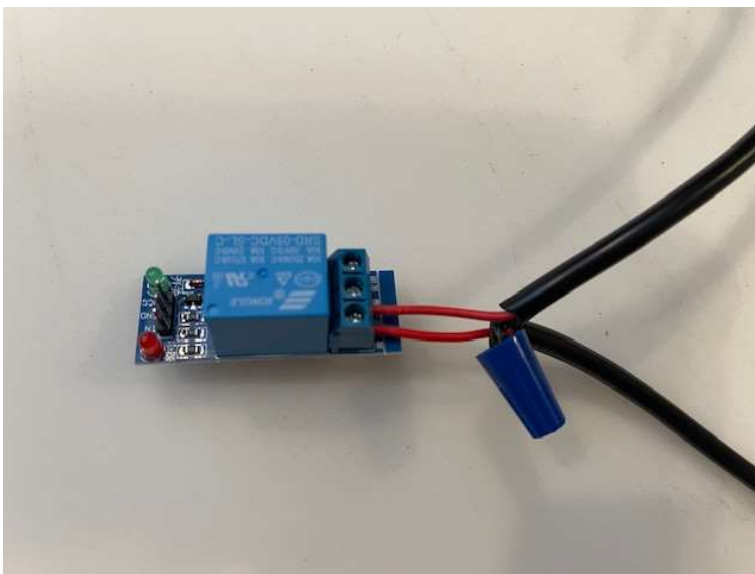

Plug the keyed end of the switch cable into the switch and route it back around the motor away from the moving arms.



Plug the blue end of the PIR cable into the PIR. Orient the PIR so that the PIR pins are on top. Plug the blue connector so that the cable that has the white line on it is on the right most pin



Plug the keyed end of the relay cable into the relay board. The white cable should go on the pin next to the red LED and the red cable should be next to the green LED.

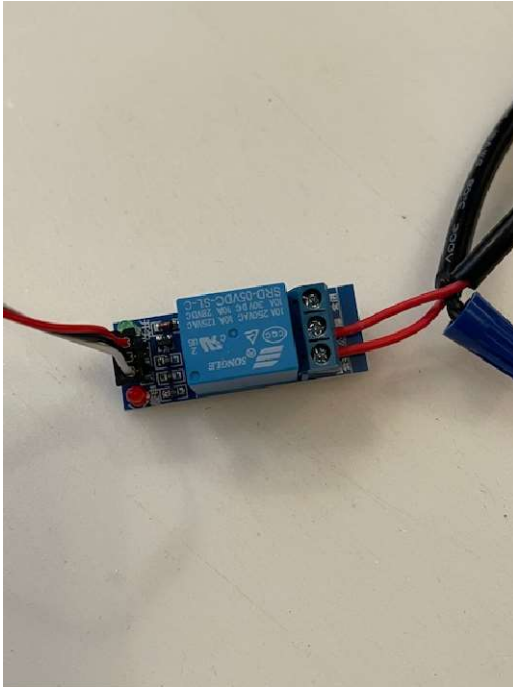

Now it is time to connect all the pins to the Arduino Nano board. Orient the board so that the USB-C port on the Nano is down. See image for details on what goes where.

PIR – The power wire (outside wire with white stripe) connects to the fourth pin from the top right. The ground wire (outside wire on the other side of the power wire) connects to the fourth pin from the top left. PIR signal wire is the middle wire and connects to the fifth pin from the top left next to the PIR ground wire.

Relay – The triple red connector connects to the second set of three pins on the top middle section on the Nano. The red power wire will be on the right while the black wire will be on the left. The white signal pin connects to the sixth pin on the top left side of the nano.

Switch – The double black connector connects to the first two pins on the top right. The red power wire will be on the first pin with the black ground wire on the second pin. The white signal pin connects to the seventh pin on the top left side of the nano.

Nano V3 Pins

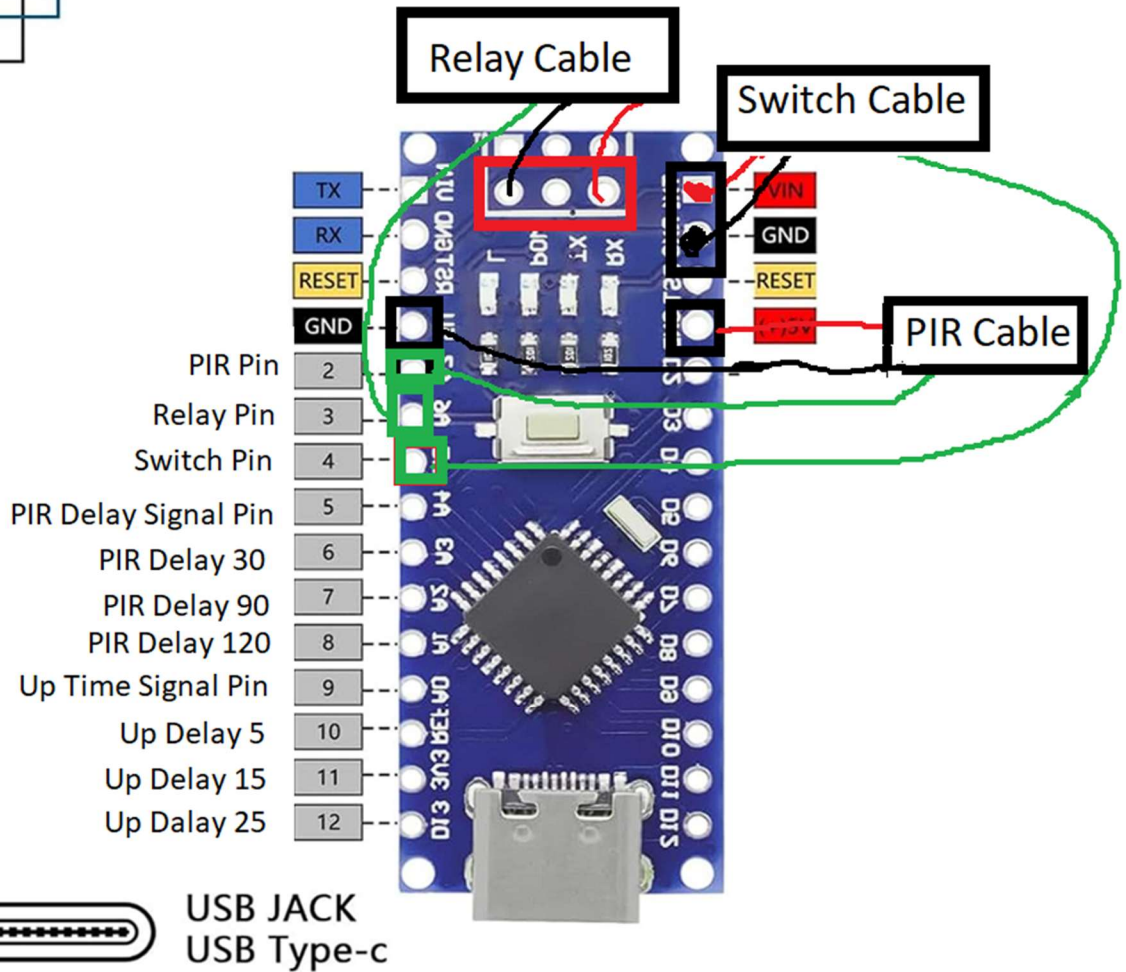
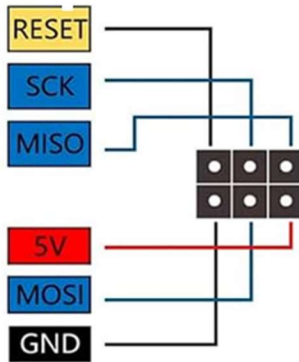

The default PIR delay is 60 seconds and the default tombstone up time is 10 seconds. The Nano is programmed so that you can change those times by running a jumper from the PIR Delay Signal Pin (eighth pin from top left) to the ninth, tenth, or eleventh (30, 90, or 120 seconds) pin. To change the "Up" tombstone time you can run a jumper from the Up Time Signal Pin (twelfth pin from the top left) to the thirteen, fourteenth, or fifteenth (5, 15, 25 seconds) pin. When there are no jumpers, the default times will be used. You can have only one jumper for the PIR delay and only one for the Up Time delay.

You will need to figure out a way to protect the components from the weather. I left space at the end of the 2X6 to mount a plastic container of some sort. What that is exactly is up to you. I am not sure how the switch will do in the rain. It might need to be covered somehow. Maybe gorilla tape down a small thin sheet of visqueen plastic over the whole thing but you will have to make sure it doesn't pull the switch arm down while it is not being pressed by the switch arm.

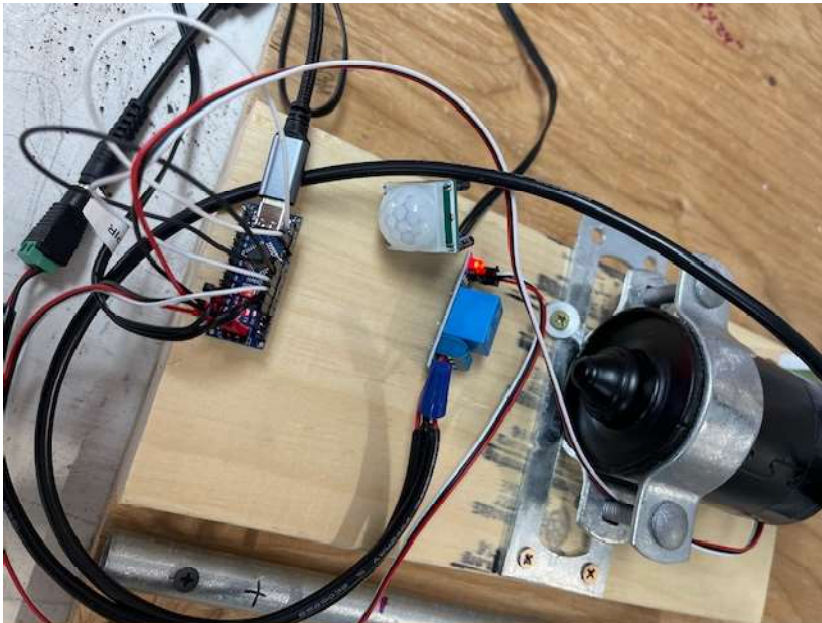

Plug in and connect the 5V 5A power brick to the 5-12V female power connector.

Plug in and connect the 5V 2A power to the Nano using the USB to USB-C cable.

Test that everything is working.

If the motor extender spins off, try using Loctite and tightening it more. If it still spins off, as a last resort, you can reverse the power connectors on motor and the motor will rotate the other direction. The down side about that is that the positive power will be on the motor housing so if something touches it that is grounded, then it will short out the power circuit.

IMPORTANT! – If you to change the direction, make sure to remove and change the direction of the micro switch before turning on the power because the rotating motor arm will most likely break the little metal micro switch arm. I learned this by experience.

Glue foam tombstone to tombstone mount

Now that your tombstone base has had time to dry, it is time to glue your tombstone to the tombstone mount. This step helps to have two people--one to hold and align the tombstone to the mount while the mount is in the lift arm, while the other person marks the back side of the foam.

You will want to arrange the tombstone foam left to right so that it covers both the uprights of the metal conduit. You will also want to make sure that the bottom of the tombstone does not drag on the prop base or on the ground in front of the base, depending on the how long your extension arm ends up being (a little on that later...). My prototype base was shorter than yours and my grass is usually a little long so I put mine up 1-1/4 to 1-1/2" from touching the ground

When you have your tombstone in place, trace around the corners of the mount onto the foam.



Remove the tombstone mount, mist it and the foam with water, put gorilla glue in a zigzag pattern around the mount and in the middle of the mount. Lay foam face down and lay the mount inside your tracing on the back side of the foam. Put toothpicks on either side of the of each corner to keep the mount from moving while the glue dries. If you have the base on your tombstone, you will might need to let it hang over the table or you will need to put something under another part of the tombstone to make it more level and place a little bit of weight on mount.

Securing the PVC pipes in your lift mechanism

Use the 1" screws to secure the PVC at each junction. You can use pipe glue to connect at the junctions. However, you will not want to use pipe glue on the the cross connectors that pivot on the metal conduit because if something breaks in your lift mechanism, you will have rebuild everything including bending a brand new conduit or unbending the existing one to get new cross connectors on the conduit.



Moving the tombstone further forward and adding weight to help the motor

You can replace the 5" extension PVC arms to give your prop that is behind the tombstone some extra room but the more you move the prop forward the harder it will be for the motor to lift the tombstone. Also, if the guy behind the tombstone is holding the tombstone, the arms will have to be longer to reach up when the tombstone is up.

If you need to extend the arms or if your motor is struggling to lift the tombstone, you can add some weight to the top of the 25" extension PVC pipe. I have some lead weights that I will probably add to it so that the motor is not as strained. Another option might be to zip tie a couple filled plastic water bottles along the length of the extension arm.



PIR info

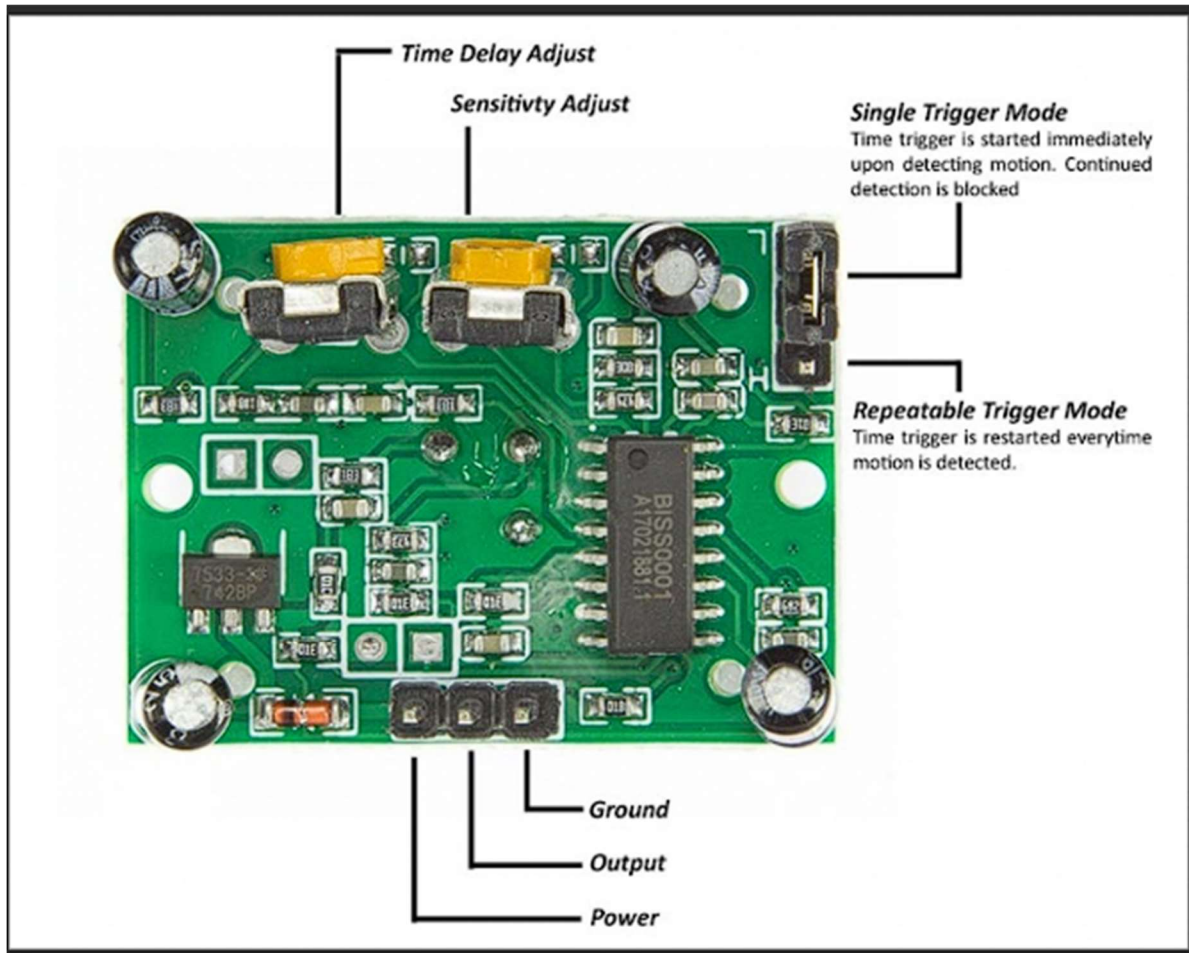

Arduino Programming

You can learn about Arduino and download the Arduino IDE from <https://www.arduino.cc/en/software/>. You can also find many how-to videos on YouTube teaching how to hook up and program an Arduino. The code I used starts on the next page.

The code for this build can be found and downloaded from <https://drive.google.com/file/d/10r8FNDuqhfZDm-NGUZG6CDMfO2Sfq9IE/view?usp=sharing>

NOTE: Converting this document to a PDF was doing some funky things with the links. Probably an Adobe hack to prevent someone from converting to a PDF without using Adobe itself. You will need to copy and paste the links and change the special character that Adobe is inserting with a "tt" (https) in both the links and "ft" (software) in the first link